

TJC-1.14/400 (2177) 型 接 触 器 用 真 空 灭 弧 室

CERAMIC VACUUM INTERRUPTER FOR CONTACTOR

主要技术参数 (MAIN TECHNICAL DATA)

参数名称 (Data)		单位 (Unit)	数值 (Value)
额定电压 Rated Voltage		kV	1.14
短时 (1min) 工频耐受电压 Short-time (1min) Power-frequency Withstand Voltage		kV	10
额定频率 Rate Frequency		Hz	50/60
使用类别 Utilization Category		AC	4
额定电流 Rated Current		A	400
额定耐受过载电流 (10s) Rated Withstand Overload Current (10s)		kA	3.2
额定短路持续时间 Rated Duration of Short-circuit		s	4
额定接通电流 Rated Making Current		kA	4
额定操作频率 Rated Operating Frequency		次/h Operations/h	120
电寿命 Electrical Endurance	AC-3	次 Operations	500000
	AC-4	次 Operations	500000
机械寿命 Mechanical Endurance		次 Operations	1000000
触头开距 Clearance Between Open Contacts		mm	3±0.5
触头自闭力 Contact Closed Force Due to Bellows and Atmosphere		N	34±10
触头反力 Counterforce of Contact at Full Stroke		N	65±20
额定触头压力下限时的回路电阻 Circuit Resistance at Min. Rated Contact Force		μΩ	≤60
触头允许磨损厚度 Contact Limit Erosion		mm	1
运动部分的质量 Mass of Moving Parts		kg	0.12
内部气体压力 Internal Gas Pressure		Pa	<1.33×10 ⁻³
允许储存期 Shelf Life		年 Year	20

配套的真空开关设备应满足的机械参数

MECHANICAL DATA OF VACUUM SWITCH EQUIPPED WITH THE INTERRUPTERS

参数名称 (Data)		单位 (Unit)	数值 (Value)
平均分闸速度 Average Opening Speed		m/s	0.55±0.1
平均合闸速度 Average Closing Speed		m/s	1±0.2
触头合闸弹跳时间 Contact Bounce Duration at Closing Operation		ms	≤3
触头合闸和分闸不同期 Out of Simultaneity of Contact Closing and Opening		ms	≤1
额定触头压力 Rated Contact Pressure		N	90 ₀ ⁺²⁰
触头最大分闸反弹量 Max.rebound of contact at opening Operation		mm	2
触头分闸允许过冲 Overtravel during opening		mm	≤2

注1: 产品符合或超过 IEC60947-4-1 以及 GB 14048.4-2003 的要求。

Note1: Meets or exceeds the electrical endurance requirements for IEC60947-4-1 and GB 14048.4-2003.

注2: 真空灭弧室动导电杆上能承受的扭力矩≤20N.m, 组装时应采取措施防止动导电杆转动, 以避免损伤波纹管。具体使用要求见《安装使用说明书》。

Note2: The movable stem of the VI could only suffering no more than 20N.m twisting force and in order not to damage the metal bellows, the movable stem should be prevent from rotation when assembling. For more requirements please check the Instructions of Usage.

灭弧室的外形尺寸、安装尺寸应符合按规定程序审批的图样要求，见图1。

TJC-1.14/400(2177)

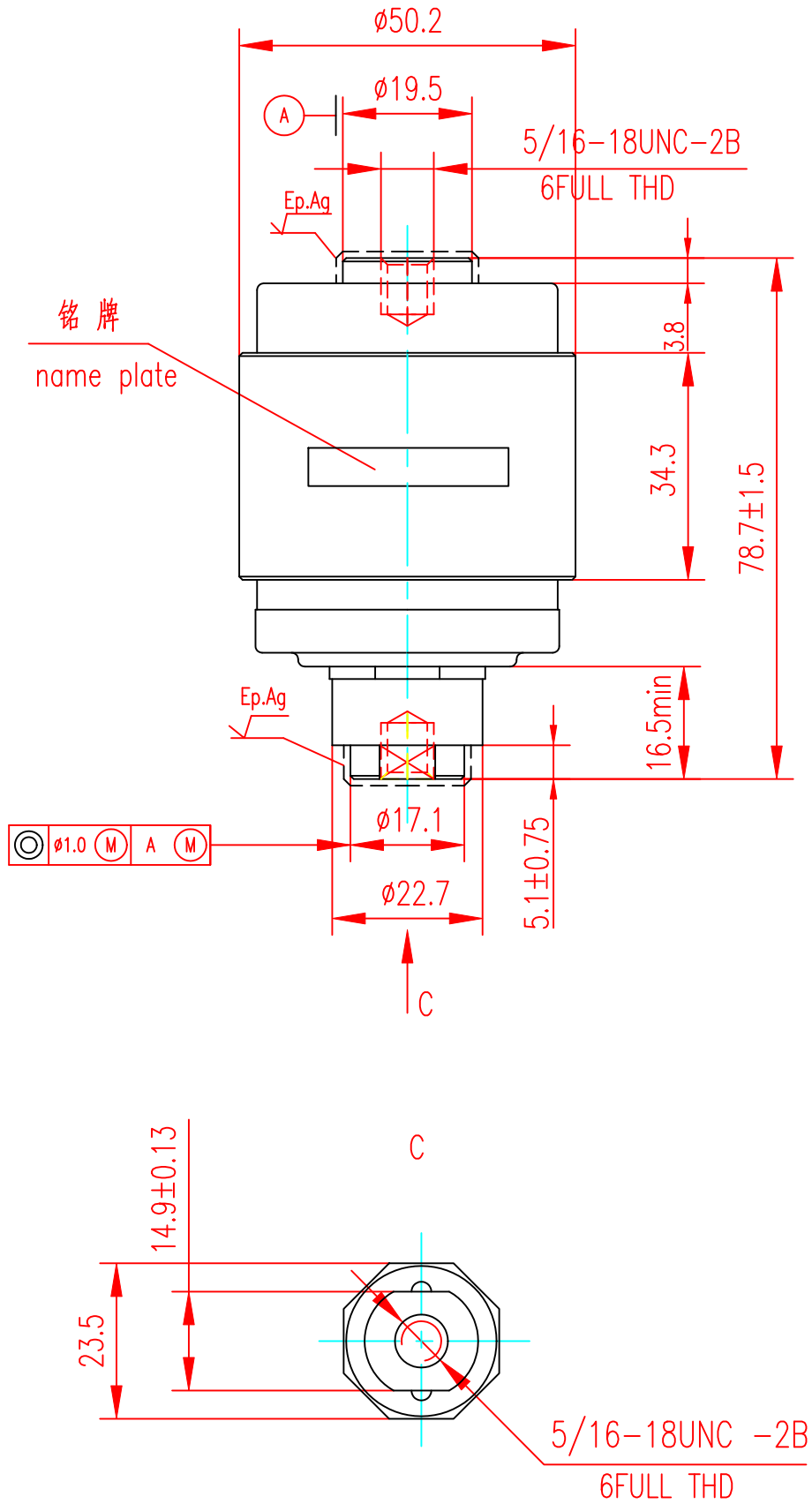

图1

责任	签字
制图	
描图	
描校	
旧底图总号	
底图总号	
日期	签字