

TD-40.5/1600-25A(2226) 型 断 路 器 用 真 空 灭 弧 室

CERAMIC VACUUM INTERRUPTER FOR CIRCUIT-BREAKER

Q/20258792-X · 667—2004 《3.6~40.5kV 交流高压断路器用真空灭弧室》适用，并作如下补充：

主要技术参数 (MAIN TECHNICAL DATA)

参数名称 (Data)	单位 (Unit)	数值 (Value)
额定电压 Rated Voltage	kV	40.5
雷电冲击耐受电压 (峰值) Lightning Impulse Withstand Voltage (Peak)	kV	185★
短时 (1min) 工频耐受电压 Short-time(1min) Power-frequency Withstand Voltage	kV	70/95★
额定频率 Rate Frequency	Hz	50
额定电流 Rated Current	A	1600
额定短时耐受电流 Rated Short-time Withstand Current	kA	25
额定短路持续时间 Rated Duration of Short-circuit	s	4
额定峰值耐受电流 Rated Peak Withstand Current	kA	63
额定短路关合电流 Rated Short-circuit Making Current	kA	63
额定短路开断电流 Rated Short-circuit Breaking Current	kA	25
最大直流分量 Max. Dc component		40%
额定短路开断电流开断次数 Switch Operations of Rated Short-circuit Breaking Current	次 Operations	20
额定单个电容器组开断电流 Rated Single Capacitor Bank Breaking Current	A	400※
额定背对背电容器组开断电流 Rated Back-to-back Capacitor Bank Breaking Current	A	400※
机械寿命 Mechanical Endurance	次 Operations	10000
触头开距 Clearance Between Open Contacts	mm	18±1
触头自闭力 Contact Closed Force Due to Bellows and Atmosphere	N	110±40
触头反力 Counterforce of Contact at Full Stroke	N	210±40
额定触头压力下限时的回路电阻 Circuit Resistance at Min. Rated Contact Force	μ Ω	≤20
触头允许磨损厚度 Contact Limit Erosion	mm	3
运动部分的质量 Mass of Moving Parts	kg	1.6
内部气体压力 Internal Gas Pressure	Pa	<1.33×10 ⁻³
允许储存期 Shelf Life	年 Year	20
额定操作顺序 Rated Operating Sequence	分-0.3秒-合分-180秒-合分 Open - 0.3s - CO - 180s - CO	

配套的真空开关设备应满足的机械参数

MECHANICAL DATA OF VACUUM SWITCH EQUIPPED WITH THE INTERRUPTERS

参数名称 (Data)	单位 (Unit)	数值 (Value)
平均分闸速度 (前 12mm) Average Opening Speed (first 12mm)	m/s	1.7±0.3
平均合闸速度 (后 6mm) Average Closing Speed (last 6mm)	m/s	1.3±0.3
触头合闸弹跳时间 Contact Bounce Duration at Closing Operation	ms	≤3
触头合闸和分闸不同期 Out of Simultaneity of Contact Closing and Opening	ms	≤2
额定触头压力 Rated Contact Pressure	N	2900 ⁺³⁰⁰ ₀
触头初压力 Contact Pressure at contact touch point		2050 ⁺²¹⁰ ₀
触头最大分闸反弹量 Max. rebound of contact at opening Operation	mm	3
触头分闸允许过冲 Overtravel during Opening	mm	≤3

注1: “★”在变压器油中或等效绝缘介质中 Note1: “★” Within transformer oil or equivalent isolation medium

注2: “※”为需要时提供的额定参数 Note2: “※” Rated characteristics to be given on request

注3: 产品符合或超过 IEC62271-100 以及 GB1984-2003 中 E2 级的要求

Note3: Meets or exceeds the electrical endurance requirements of class E2 for autoreclosing duty per IEC 62271-100 and GB1984-2003

注4: 真空灭弧室动导电杆上能承受的扭力矩≤25N.m, 组装时应采取措施防止动导电杆转动, 以避免损伤波纹管。具体使用要求见《安装使用说明书》。

Note4: The movable stem of the VI could only suffering no more than 25N.m twisting force and in order not to damage the metal bellows, the movable stem should be prevent from rotation when assembling. For more requirements please check the Instructions of Usage.

灭弧室的外形尺寸、安装尺寸应符合按规定程序审批的图样要求，见图1。

TD-40.5/1600-25A(2226)

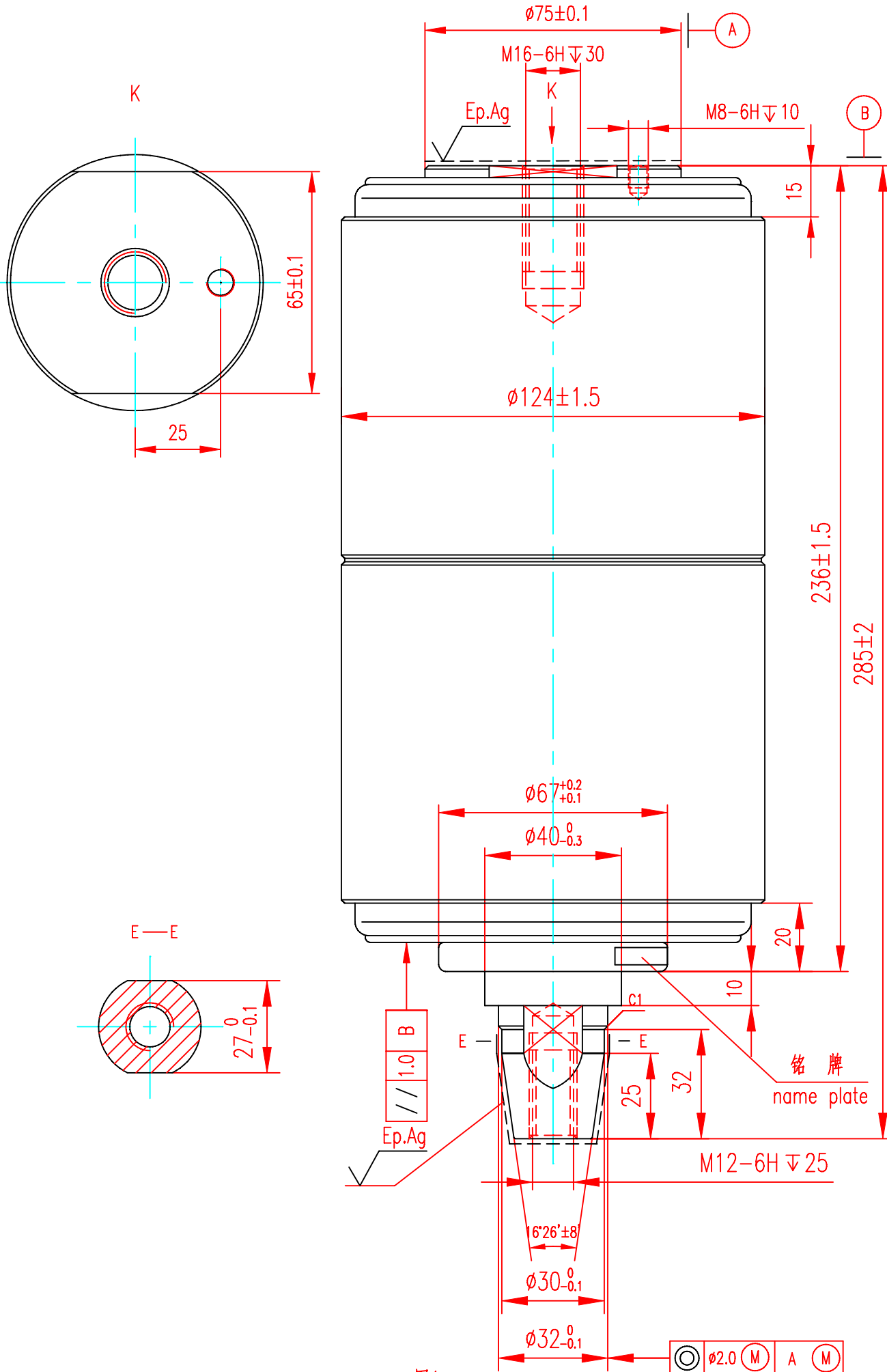

图1

责任	签字
制图	
描图	
描校	
旧底图总号	
底图总号	
日期	签字