

HYD-24/3150(2500)-31.5 (9039) 型 断路器用环氧固封极柱
EMBEDDED POLE WITH EPOXY FOR CIRCUIT-BREAKER

Q/20258792-X·521—2005《3.6~40.5kV 交流高压断路器用环氧固封极柱》适用，并作如下补充：
主要技术参数 (MAIN TECHNICAL DATA)

参数名称 (Data)	单位 (Unit)	数值 (Value)
额定电压 Rated Voltage	kV	24
雷电冲击耐受电压 (峰值) Lightning Impulse Withstand Voltage (Peak)	kV	145
短时 (1min) 工频耐受电压 Short-time (1min) Power-frequency Withstand Voltage	kV	79
额定频率 Rate Frequency	Hz	50
额定电流 Rated Current	A	3150(2500)
额定短时耐受电流 Rated Short-time Withstand Current	kA	31.5
额定短路持续时间 Rated Duration of Short-circuit	s	4
额定峰值耐受电流 Rated Peak Withstand Current	kA	80
额定短路关合电流 Rated Short-circuit Making Current	kA	80
额定短路开断电流 Rated Short-circuit Breaking Current	kA	31.5
最大直流分量 Max. Dc component		50%
额定短路开断电流开断次数 Switching Operations of Rated Short-circuit Breaking	次 Operations	30
额定单个电容器组开断电流 Rated Single Capacitor Bank Breaking Current	A	400※
额定背对背电容器组开断电流 Rated Back-to-back Capacitor Bank Breaking Current	A	400※
机械寿命 Mechanical Endurance	次 Operations	10000
触头开距 Clearance Between Open Contacts	mm	13±1
触头自闭力 Contact Closed Force Due to Bellows and Atmosphere	N	240±40
触头反力 Counterforce of Contact at Full Stroke	N	350±40
额定超行程下限时的回路电阻 Circuit Resistance at Min. Rated Over-travel	μΩ	≤15
触头允许磨损厚度 Contact Limit Erosion	mm	3
运动部分的质量 Mass of Moving Parts	kg	5.0±0.3
内部气体压力 Internal Gas Pressure	Pa	<1.33×10 ⁻³
允许储存期 Shelf Life	年 Year	20
局部放电量 (26.4kV) Magnitude Of Partial Discharge (26.4kV)	pC	≤5
波纹管防扭力矩 Torsionproof Moment Of Bellows	N·m	≤45
额定操作顺序 Rated Operating Sequence	分-0.3秒-合分-180秒-合分 0 - 0.3s - CO - 180s - CO	

配套的真空开关设备应满足的机械参数

MECHANICAL DATA OF VACUUM SWITCH EQUIPPED WITH THE INTERRUPTERS

参数名称 (Data)	单位 (Unit)	数值 (Value)
平均分闸速度 (前 6mm) Average Opening Speed (first 6mm)	m/s	1.3±0.2
平均合闸速度 (后 6mm) Average Closing Speed (last 6mm)	m/s	0.6±0.2
触头合闸弹跳时间 Contact Bounce Duration at Closing Operation	ms	≤2
触头合闸和分闸不同期 Out of Simultaneity of Contact Closing and Opening	ms	≤2
额定超行程 Rated Over-travel	mm	4±1
额定超行程下限时的触头压力 Contact Pressure at Min. Rated Over-travel	N	3100±200
触头最大分闸反弹量 Max. rebound of contact at opening Operation	mm	2
触头分闸允许过冲 Overtravel during Opening	mm	≤2

注 1: “※” 为需要时提供的额定参数;

Note 1: “※” Rated characteristics to be given on request;

注 2: 产品符合或超过 ICE62271-100 以及 GB1984-2003 中 E2 级的要求。

Note 2: Meets or exceeds the electrical endurance requirements of class E2 for IEC 62271-100 and GB1984-2003.

会 签

固封极柱的外形尺寸、安装尺寸应符合按规定程序审批的图样要求，见图1。

HYD-24/3150-31.5(9039)

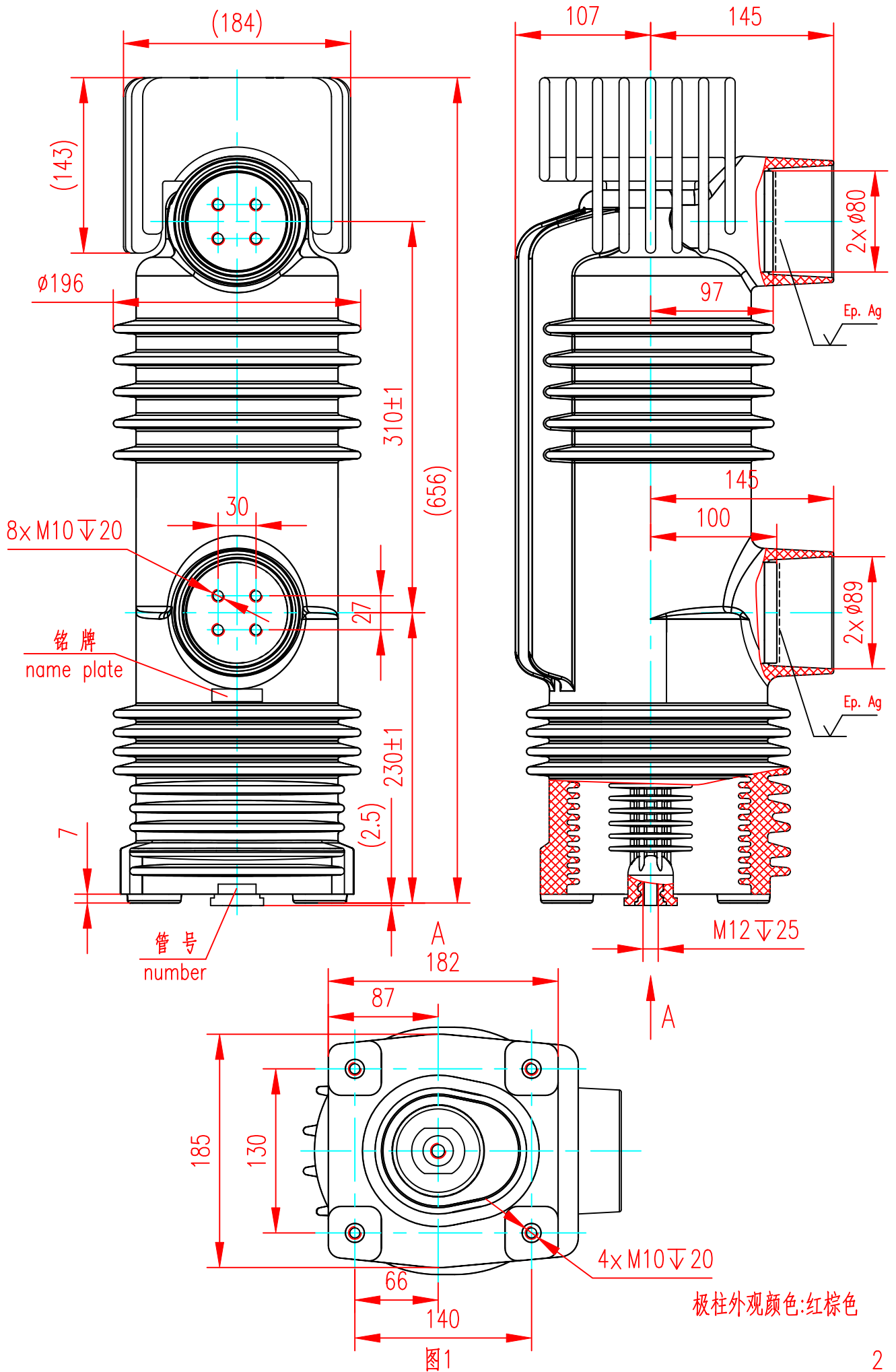

图1

责任	签字
制图	
描图	
描校	
旧底图总号	
底图总号	
日期	签字