

TD-1.14/2500-65H (2180) 型 断 路 器 用 真 空 灭 弧 室
CERAMIC VACUUM INTERRUPTER FOR CIRCUIT-BREAKER

Q/20258792-X·667—2004《3.6~40.5kV 交流高压断路器用真空灭弧室》适用，并作如下补充：

主要技术参数 (MAIN TECHNICAL DATA)

参数名称 (Data)	单位 (Unit)	数值 (Value)
额定电压 Rated Voltage	kV	1.14
短时 (1min) 工频耐受电压 Short-time (1min) Power-frequency Withstand Voltage	kV	10
额定频率 Rate Frequency	Hz	50
额定电流 Rated Current	A	2500
额定短时耐受电流 Rated Short-time Withstand Current	kA	65
额定短路持续时间 Rated Duration of Short-circuit	s	1
额定短路接通能力 Rated Short-circuit Making Capability	kA	143
额定短路分断能力 Rated Short-circuit Breaking Capability	kA	65
额定极限短路分断能力 Rated Limit Short-circuit Breaking Capability	kA	65
额定运行短路分断能力 Rated Operating Short-circuit Breaking Capability	kA	65
机械寿命 Mechanical Endurance	次 Operations	10000
电寿命 Electrical Endurance	次 Operations	10000
触头开距 Clearance Between Open Contacts	mm	4±0.5
触头自闭力 Contact Closed Force Due to Bellows and Atmosphere	N	120±30
触头反力 Counterforce of Contact at Full Stroke	N	180±30
额定触头压力下限时的回路电阻 Circuit Resistance at Min. Rated Contact Force	μΩ	≤15
触头允许磨损厚度 Contact Limit Erosion	mm	3
运动部分的质量 Mass of Moving Parts	kg	2.4
内部气体压力 Internal Gas Pressure	Pa	<1.33×10 ⁻³
允许储存期 Shelf Life	年 Year	20

配套的真空开关应满足的机械参数

MECHANICAL DATA OF VACUUM SWITCH EQUIPPED WITH THE INTERRUPTERS

参数名称 (Data)	单位 (Unit)	数值 (Value)
平均分闸速度 Average Opening Speed	m/s	1.1±0.1
平均合闸速度 Average Closing Speed	m/s	0.5±0.1
触头合闸弹跳时间 Contact Bounce Duration at Closing Operation	ms	≤2
触头合闸和分闸不同期 Out of Simultaneity of Contact Closing and Opening	ms	≤1
额定触头压力 Rated Contact Pressure	N	5000 ₀ ⁺²⁰⁰
触头初压力 Contact Pressure at contact touch point		3500 ₀ ⁺²⁰⁰
触头最大分闸反弹量 Max. rebound of contact at opening Operation	mm	2
触头分闸允许过冲 Overtravel during Opening	mm	≤2

注1: 产品符合或超过 IEC62271-100 以及 GB1984-2003 中 E2 级的要求

Note1: Meets or exceeds the electrical endurance requirements of class E2 for autoreclosing duty per IEC 62271-100 and GB1984-2003

注2: 真空灭弧室动导电杆无防扭, 组装时应采取措施防止动导电杆转动, 以避免损伤波纹管。具体使用要求见《安装使用说明书》。

Note2: The movable stem of the VI could not suffering twisting force and in order not to damage the metal bellows, the movable stem should be prevent from rotation when assembling. For more requirements please check the Instructions of Usage.

会 签

Q/20258792-X·2180--2005

灭弧室的外形尺寸、安装尺寸应符合按规定程序审批的图样要求, 见图1。

TD-1.14/2500-65H(2180)

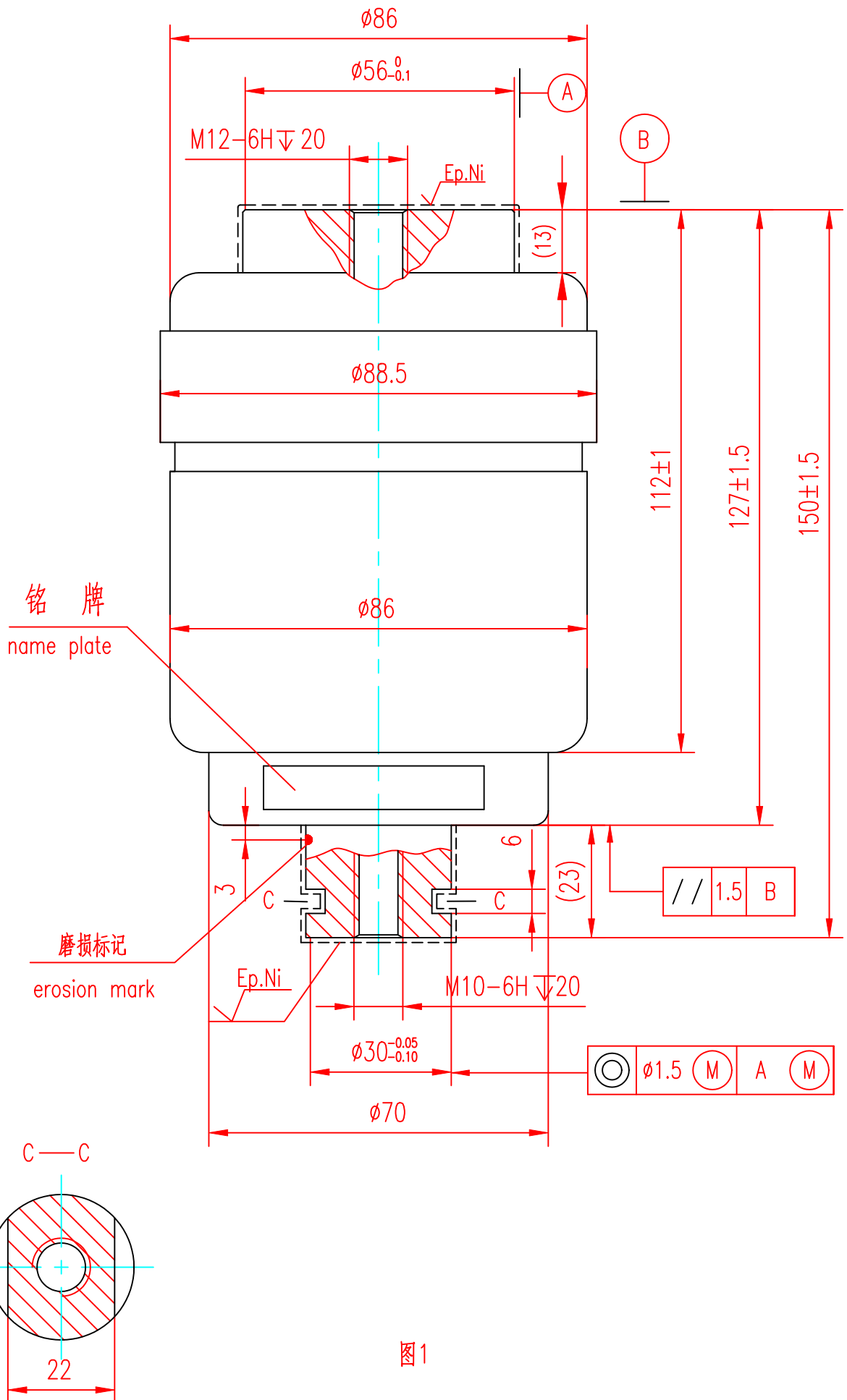

图 1

责任	签字
制图	
描图	
描校	
旧底图总号	
底图总号	
日期	签字